



杰美康机电  
JUST MOTION CONTROL

# iHSV

**Integrated ac servo motor  
manual**

---

## Introduction

All contents of this manual, copyright owned by Shenzhen Just Motion Control Electromechanics Co.,Ltd., shall not be arbitrarily reproduced, copied, transcribed without permission. This manual does not contain any forms of guarantee, standpoint statement, or hint. Shenzhen Just Motion Control and its employees will not take any responsibility for the loss caused by direct or indirect leaking information mentioned in this Manual. In addition, products information in this manual is for reference only, we are sorry for not offering update if it is improved.

Shenzhen Just Motion Control Electro-mechanics Co., Ltd

Shenzhen Just Motion Control Electro-mechanics Co., Ltd

TEL:+86-0755-26509689

FAX:+86-0755-26509289

www.jmc-motion.com

Email: info@jmc-motion.com

Address: Floor2, Building A, Hongwei Industrial Zone No.6,

Liuxian 3rd Road, Shenzhen. China

Version	Editor	Verifier
V2.0	R&D	R&D

## Contents

<b>1. Overview</b> .....	<b>Error! Bookmark not defined.</b>
<b>2. Features</b> .....	4
<b>3. Technical index</b> .....	4
<b>4. Ports Introduction</b> .....	5
4.1 ALM signal output ports.....	5
4.2 Control Signal Input Ports.....	5
4.3 Power Interface Ports.....	6
<b>5. Parameter and function</b> .....	6
5.1 List of parameters.....	6
5.2 Parameter parsing instructions.....	11
5.2.1 P00-xx Motor and Drive Parameters.....	11
5.2.2 P01-xx Main control parameters.....	13
5.2.3 P02-xx Gain parameters.....	21
5.2.4 P03-xx Position parameters.....	177
5.2.5 P04-xx Speed parameter.....	18
5.2.6 P05-xx 8/5000Torque parameters.....	19
5.2.7 P06-xx I/O parameter.....	190
5.2.8 P08-xx Advanced function parameters.....	30
5.3 List of monitored items.....	31
<b>6. Fault Analysis and Processing</b> .....	22
6.1 Fault Alarm Information Form.....	22
6.2 Causes and Disposal of Fault Alarm.....	36
<b>7. Control signal wiring</b> .....	40
7.1 Control signal single terminal coanode wiring.....	260
7.2 Control signal single terminal cocathode wiring.....	27
7.3 Control signal differential wiring mode.....	27
7.4 232Serial communication wiring.....	28
7.5 Control signal timing diagram.....	29
7.6 Chart of torque characteristic of servo motor speed.....	30
<b>8. Subdivision code switch settings</b> .....	50
8.1 Subdivision settings.....	50
8.2 Enter Edge Settings.....	51
8.3 logical Direction Settings.....	51
<b>9. Error alarm and LED light flicker times</b> .....	51
<b>10. Installation dimensions(mm)</b> .....	<b>52</b>
<b>11. Frequently Asked Questions and Fault Analysis</b> .....	<b>56</b>
11.1 Power's not on.....	56
11.2Turn on the red light.....	56
11.3 Run, turn a small angle, turn on the red light.....	56
11.4 After the pulse is entered, it does not rotate.....	56
<b>12. IHSV42/57/60/86-XX Parameter modification step</b> .....	<b>57</b>

## 1. Overview

IHSV42/57/60 / 86-XX Integrated AC servo drive motor integrates AC servo drive into servo motor. The two are perfectly integrated and use vector control designed and produced by DSP. It has the characteristics of low cost, full closed-loop, full number, low heat, small vibration and fast response. Includes three adjustable feedback loop controls(position loop, speed loop, and current loop). Performance stability, is a very high cost performance of sports control products.

## 2. Features

- 2.1 Multiple pulse input modes Pulse + Direction
- 2.2 Optically coupled isolation servo reset input interface ERC
- 2.3 Current loop bandwidth:(-3 dB) 2 KHz(typical value)
- 2.4 Speed loop bandwidth: 500 Hz(typical value)
- 2.5 Position loop bandwidth: 200 Hz(typical value)
- 2.6 Motor end orthogonal encoder input interface: differential input(26LS32)
- 2.7 Download parameters via PC or text display with RS232C interface
- 2.8 Users can choose to subdivide through external dialing switches, or they can use software Define subdivision
- 2.9 Overflow, I2T, Overpressure, Speeding, Ultra-Poor Protection
- 2.10 A green light indicates operation, a red light indicates protection or offline

## 3. Technological Index

		42base		57base			60base		86base	
		52 W	78 W	100 W	140 W	180 W	200 W	400 W	440 W	660 W
		24V		36V			36V	48V	48V	72V
Max pulse frequency		200K								
Default communication rate		9.6Kbps ( Additional interface required )								
Protection		►Overload I2t Current Action Value 300 % 3S								
Specifications	Environment	Avoid dust, oil fog and corrosive gases								
	Working temperature	0~+70℃								
	Storage temperature	-20℃~+80℃								
	Humidity	40~90%RH								
	Cooling method	Natural cooling or forced air cooling								

## 4、 Ports Introduction

### 4.1 ALM signal output ports

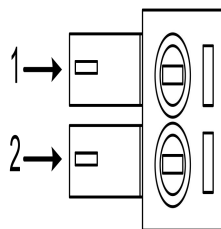

Symbol	Name	Instruction
ALM-	Alarm output -	
ALM+	Alarm output +	
PED-	Arrive position output-	
PED+	Arrive position output+	

### 4.2 Control Signal Input Ports

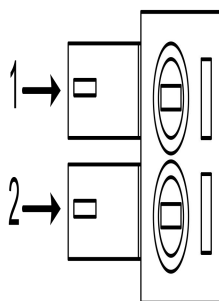

Symbol	Function	Remark
ENA-	Enabling signal: This input signal is used to enable or prohibit; In addition, it can be used to clear the drive alarm. When ENA + is connected to +5 V, ENA-is connected to	Low 0 ~ 0.5 V valid
ENA+	low power, the drive will cut off the current of each phase of the motor so that the motor is in a free state, where the pulse is not responded and the alarm can be cleared; When this function is not required, the energy signal end is suspended.	High 4 ~ 5V valid
DIR-	Direction signal: high/low level signal. In order to ensure	Low 0 ~ 0.5 V valid
DIR+	the reliable direction change of the motor, the direction signal should be established before the pulse signal at least	High 4 ~ 5V valid

	6us.	
PUL-	Pulse control signal: Pulse rising edge is effective. In order	Low 0 ~ 0.5 V valid
PUL+	to reliably respond to pulse signal, the pulse width should be greater than 2.5 us.	High 4 ~ 5V valid

### 4.3 Power port

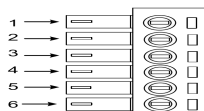

Identification	Symbol	Name	Remark
Power input terminal	DC+	Power+	20VDC-80VDC(select voltage and power supply according to the corresponding type of motor's technical index)
	GND	Power -	

## 5、 Parameters and function

### 5.1 Parameters list

P00-xx Represents motor and drive parameters

P01-xx Main control parameters

P02-xx Represents the gain class parameter

P03-xx Represents the position parameter

P04-xx Represents the speed parameter

P05-xx Represent the torque speed

P06-xx Represent I/O parameter

P08-xx Represents an advanced function parameter

Model	Parameter code	Name	Setting range	Factory setting	Unit	Setting way	Effective time
	P00-00	Motor No.	0-65535	---		Stop Setting	Re-power
	P00-01	Motor rated speed	1-6000	---	rpm	Stop Setting	Re-power
	P00-02	Motor rated torque	0.01-655.35	---	N.M	Stop Setting	Re-power

Motor and driver parameters	P00-03	Motor rated current	0.01-655.35	---	A	Stop Setting	Re-power
	P00-04	Motor inertia	0.01-655.35	---	kg.cm <sup>2</sup>	Stop Setting	Re-power
	P00-05	Pole number of motor	1-31	---	Opposite pole	Stop Setting	Re-power
Motor and driver parameters	P00-10	Number of lines in incremental encoder	0-65535	---		Stop Setting	Re-power
	P00-11	Incremental encoder Z pulse angle	0-65535	---		Stop Setting	Re-power
	P00-12	Initial angle of rotor 1	0-360	---	1degree	Stop Setting	Re-power
	P00-13	Initial angle of rotor2	0-360	---	1degree	Stop Setting	Re-power
	P00-14	Initial angle of rotor3	0-360	---	1degree	Stop Setting	Re-power
	P00-15	Initial angle of rotor4	0-360	---	1degree	Stop Setting	Re-power
	P00-16	Initial angle of rotor5	0-360	---	1degree	Stop Setting	Re-power
	P00-17	Initial angle of rotor6	0-360	---	1degree	Stop Setting	Re-power
	P00-21	RS232 communicate baud rate	0-3	2	---	Stop Setting	Re-power
	P00-23	Slave address	0-255	1	---	Stop Setting	Re-power
	P00-24	Modbus communicate baud rate	0-7	7	---	Stop Setting	Re-power
	P00-25	Check mode	0-3	1	---	Stop Setting	Re-power
	P00-26	ModbusCommunication response delay	0-100	0	1ms	Stop Setting	Re-power
	P00-42	Overvoltage protection threshold	0-300	0	1V	Stop Setting	Re-power
	Main control parameters	P01-01	Control mode setting	0-2	0	---	Stop Setting
P01-02		Real time automatic adjustment	0-2	1	---	Run Settings	Effective immediately

		mode					
	P01-03	Real time automatic adjustment of rigidity setting	0-31	13	---	Run Settings	Effective immediately
	P01-04	The ratio of moment of inertia	0-100.00	1	1times	Run Settings	Effective immediately
	P01-30	Brake command - servo OFF delay time (brake open delay)	0-255	100	1ms	Run Settings	Effective immediately
	P01-31	Speed limit value of brake command output	0-3000	100	1rpm	Run Settings	Effective immediately
	P01-32	Servo OFF brake command waiting time	0-255	100	1ms	Run Settings	Effective immediately
Gain parameter	P02-00	Position control gain 1	0-3000.0	48.0	1/S	Run Settings	Effective immediately
	P02-01	Position control gain 2	0-3000.0	57.0	1/S	Run Settings	Effective immediately
	P02-03	Speed feedforward gain	0-100.0	30.0	1.0%	Run Settings	Effective immediately
	P02-04	Speed feedforward smoothing constant	0-64.00	0.5	1ms	Run Settings	Effective immediately
	P02-10	Speed proportional gain1	1.0-2000.0	27.0	1Hz	Run Settings	Effective immediately
Gain parameter	P02-11	Speed integral constant 1	0.1-1000.0	10.0	1ms	Run Settings	Effective immediately
	P02-12	Pseudo differential feedforward control coefficient1	0-100.0	100.0	1.0%	Run Settings	Effective immediately



	P02-13	Speed proportional gain 2	1.0-2000.0	27.0	1Hz	Run Setting s	Effective immediately
	P02-14	Velocity integral constant2	0.1-1000.0	1000.0	1ms	Run Setting s	Effective immediately
	P02-15	Pseudo differential feedforward control coefficient2	0-100.0	100.0	1.0%	Run Setting s	Effective immediately
	P02-19	Torque feedforward gain	0-30000	0	1.0%	Run Setting s	Effective immediately
	P02-20	Torque feed forward smoothing constant	0-64.00	0.8	1ms	Run Setting s	Effective immediately
	P02-30	Gain switching mode	0-10	0	---	Run Setting s	Effective immediately
	P02-31	Gain switching level	0-20000	800	---	Run Setting s	Effective immediately
	P02-32	Gain switching delay	0-20000	100	---	Run Setting s	Effective immediately
	P02-33	Gain switching delay	0-1000.0	10.0	1ms	Run Setting s	Effective immediately
	P02-34	Position gain switching time	0-1000.0	10.0	1ms	Run Setting s	Effective immediately
	P02-41	Mode switch level	0-20000	10000	---	Run Setting s	Effective immediately
	P02-50	The torque instruction is added	-100.0-100.0	0	1.0%	Run Setting s	Effective immediately
	P02-51	Forward torque compensation	-100.0-100.0	0	1.0%	Run Setting s	Effective immediately
	P02-52	Reverse torque compensation	-100.0-100.0	0	1.0%	Run Setting s	Effective immediately
	P03-00	Location command source	0-1	0	---	Stop Setting	Effective immediately
	P03-03	The command	0-1	0	---	Stop	Effective

location parameter		pulse is reversed				Setting	immediately
	P03-04	Position pulse filtering	0-3	2	---	Run Settings	Effective immediately
	P03-05	Positioning completes the judgment condition	0-2	1	---	Run Settings	Effective immediately
	P03-06	Location Completion range	0-65535	30	Encoder unit	Run Settings	Effective immediately
	P03-09	Number of command pulses for one motor rotation	0-65535	4000	Pulse	Run Settings	Re-power
	P03-10	Molecular of electronic gear 1	1-65535	4000	---	Run Settings	Re-power
	P03-11	The denominator of electronic gear 1	1-65535	4000	---	Run Settings	Re-power
	P03-15	Position deviation too large setting	0-65535	0	Instruction unit*10	Run Settings	Effective immediately
	P03-16	Position instruction smoothing filter time constant	0-1000.0	0	1ms	Run Settings	Effective immediately
speed parameter	P04-00	Speed command source	0-1	1	---	Stop Setting	Effective immediately
	P04-02	Digital speed given value	-6000—6000	0	1rpm	Run Settings	Effective immediately
	P04-05	Speed alarm value	0-6500	6400	1rpm	Run Settings	Effective immediately
	P04-06	Forward speed limit	0-6000	5000	1rpm	Run Settings	Effective immediately
	P04-07	Reverse speed limit	0-6000	-5000	1rpm	Run Settings	Effective immediately
	P04-10	Zero speed detection value	0-200.0	40	1rpm	Run Settings	Effective immediately

	P04-14	Speed time	0-10000	500	1ms/100 0rpm	Run Settin gs	Effective immediately
	P04-15	Deceleration time	0-10000	500		Run Settin gs	Effective immediately
torque param eter	P05-10	Internal positive torque limit value	0-300.0	200.0	1.0%	Run Settin gs	Effective immediately
	P05-11	Internal torque limit value	0-300.0	200.0	1.0%	Run Settin gs	Effective immediately
I/O Param eter	P06-00	Enable input port effective level	0-4	1	---	Run Settin gs	Re-power
	P06-20	Alarm output port effective level	0-1	1	---	Run Settin gs	Re-power
	P06-22	Output port in place valid level	0/1	1	---	Run Settin gs	Re-power
Advan ced functi on param eters	P08-19	low pass filter constant of Feedback speed	0-25.00	0.8	1ms	Run Settin gs	Effective immediately
	P08-20	Torque command filter constant	0-25.00	0.84	1ms	Run Settin gs	Effective immediately
	P08-25	Disturbing torque compensation gain	0-100.0	0	%	Run Settin gs	Effective immediately
	P08-26	Disturbing torque filter time constant	0-25.00	0.8	1ms	Run Settin gs	Effective immediately

## 5.2 Description of parameter analysis

### 5.2.1 P00-xx Motor and driver parameters

Parame ter code	Name	Instruction
P00-00	Motor number	Factory set, no need to set 0: P0-01 to P0-17 play a role
P00-01	Motor rated speed	Setting range : 1-6000, Unit: rpm Factory setting has done ,no need to set
P00-02	Motor rated torque	Setting range: 0.01-655.35, Unit: N.M Setting according to the matched motor, factory setting has done
P00-03	Rated current of motor	Setting range: 0.01-655.35, unit: A According to the motor settings, the factory has been set up.
P00-04	Motor moment	Setting range: 0.01-655.35, unit: kg.cm <sup>2</sup>

	of inertia	Setting according to the matched motor , factory setting has done
P00-05	Pole number of motor	Set range: 1-31, unit: opposite pole ,Setting according to the matched motor , factory setting has done
P00-10	Incremental encoder number	Setting according to the matched motor , factory setting has done
P00-11	Incremental encoder Z pulse Angle	Setting according to the matched motor , factory setting has done
P00-12	Initial rotor Angle 1	Setting according to the matched motor , factory setting has done
P00-13	Initial rotor Angle 2	Setting according to the matched motor , factory setting has done
P00-14	Initial rotor Angle 3	Setting according to the matched motor , factory setting has done
P00-15	Initial rotor Angle 4	Setting according to the matched motor , factory setting has done
P00-16	Initial rotor Angle 5	Setting according to the matched motor , factory setting has done
P00-17	Initial rotor Angle 6	Setting according to the matched motor , factory setting has done
P00-21	RS232Communication baud rate selection	Setting range : 0-3 Select the baud rate when communicating with PC0: 9600 1: 19200 2: 57600 3: 115200
P00-23	Slave station address	Setting range: 0—255, the default value is 1 Set up according to equipment requirements
P00-24	Modbus Communication baud rate	Setting range : 0-7, The default value is 2 0:2400 1:4800 2:9600 3:19200 4:38400 5:57600 6:115200 7:25600
P00-25	Check way	Setting range: 0-3, default value : 1 0: no check, two stop bits 1: even check, 1 stop bit 2: odd check, 1 stop bit 3: no check, 1 stop bit
P00-26	Modbus Communication response delay	Setting range: 0-100, Unit ms
P00-42	Overvoltage protection threshold	Setting range: 0-300, unit V

**5.2.2 P01-xx Master control parameter**

Parameter code	name	Instruction
P01-01	Control mode setting	Setting range: 0-6 0: position control mode 1: speed control mode 2: torque control mode
P01-02	Real time automatic adjustment mode	332/5000 Setting range: 0-2 0: manually adjust the rigidity. 1: standard mode automatically adjusts rigidity. In this mode, parameters p02-00, p02-01, p02-10, p02-11, p02-13, p02-14, and p08-20 will be set automatically according to the rigidity level set by p01-03. Manual adjustment of these parameters will not work. The following parameters are set by the user: P02-03 (speed feed-forward gain), p02-04 (speed feed-forward smoothing constant). 2: positioning mode automatically adjusts rigidity. In this mode, parameters p02-00, p02-01, p02-10, p02-11, p02-13, p02-14, and p08-20 will be set automatically according to the rigidity level set by p01-03. Manual adjustment of these parameters will not work. The following parameters will be fixed and cannot be changed: P02-03 (speed feedforward gain) : 30.0% P02-04 (speed feed-forward smoothing constant) : 0.50
P01-03	Adjust the rigid setting automatically in real time	Setting range: 0-31 Built-in 32 gain class parameters, when p01-02 set to 1, or 2. Can be called directly according to the actual situation, the larger the set value, the stronger the rigidity.
P01-04	Moment of inertia ratio	Setting range: 0-100, unit: times Set the load inertia ratio of the corresponding motor. The setting method is as follows: P01-04= load inertia/motor moment of inertia This inertia ratio can use the value identified by AF-J-L automatic inertia identification and write the value into the parameter
P01-30	Brake command - servo OFF delay time (brake opening delay)	Setting range: 0-255, unit: ms When open the Enable: after the enable instruction is executed, the drive will receive the position instruction after the time of p01-30. When turn off the enable when the motor is in a state of rest, the time after the energy command is executed and the holding gate is closed until the motor becomes non-energized.
P01-31	Speed limit value of brake instruction output	Setting range: 0-3000 Unit RPM When the motor is in a state of rotation, the motor speed threshold when the brake output is valid. If it is lower than this threshold, the brake output command is effective; otherwise, it

		will wait for p01-32 time before the gate output command is effective.
P01-32	Servo OFF- lock instruction wait time	Setting range: 0-255, unit: ms When the motor is in a state of rotation, the maximum waiting time for the output of the holding gate.

### 5.2.3 P02-xx Gain class parameter

Parameter code	Name	Instruction
P02-00	Position control gain 1	Setting range: 0-3000.0, unit: 1/S As for the proportional gain of the position loop regulator, the larger the parameter value, the higher the gain ratio, the higher the stiffness, the smaller the position tracking error and the faster the response. However, too large parameters can easily cause vibration and overshoot. This parameter is for the steady-state response.
P02-01	Position control gain 2	Setting range: 0-3000.0, unit: 1/S As for the proportional gain of the position loop regulator, the larger the parameter value, the higher the gain ratio, the higher the stiffness, the smaller the position tracking error and the faster the response. However, too large parameters can easily cause vibration and overshoot. This parameter is for dynamic response.
P02-03	Speed feed forward gain	Setting range: 0-100.0, unit: 1.0% The feed forward gain of the speed loop, the larger the parameter value, the smaller the system position tracking error, and the faster the response. However, if the feedforward gain is too large, the position loop of the system will be unstable, which will easily cause overshoot and shock.
P02-04	Speed feedforward smoothing constant	Setting range: 0-64.00, unit: ms This parameter is used to set the speed loop feed-forward filter time constant. The larger the value, the larger the filtering effect, but at the same time the phase lag increases.
P02-10	Speed proportional gain 1	Setting range: 1.00-2000.0, unit: Hz The larger the speed proportional gain, the larger the servo stiffness, the faster the speed response, but too large is easy to generate vibration and noise. This parameter value is increased as far as possible under the condition that the system is not oscillating. This parameter is for static responses.
P02-11	Speed integral constant 1	Setting range: 1.0-1000.0, unit: ms Speed regulator integral time constant. The smaller the setting value is, the faster the integral velocity is and the higher the stiffness is. This parameter value is minimized when the system does not oscillate. This parameter is for the steady-state response.
P02-12	Pseudo	Setting range: 0-100.0, unit: 1.0%

	differential feed forward control factor 1	When the speed loop is set to 100.0%, PI control is adopted and the dynamic response is fast. When set to 0, the velocity loop integral has obvious effect and can filter low frequency interference, but the dynamic response is slow. By adjusting this coefficient, the speed loop can have better dynamic response and increase the resistance of low frequency interference.									
P02-13	Speed proportional gain 2	Setting range: 1.00-2000.0, unit: Hz The larger the speed proportional gain, the larger the servo stiffness, the faster the speed response, but too large is easy to generate vibration and noise. This parameter value is increased as far as possible under the condition that the system is not oscillating. This parameter is for dynamic response.									
P02-14	The speed integral constant 2	Setting range: 1.0-1000.0, unit: ms  Speed regulator integral time constant. The smaller the setting value is, the faster the integral velocity is and the higher the stiffness is.  This parameter value is minimized when the system does not oscillate. This parameter is for dynamic response.									
P02-15	Pseudo differential feedforward control coefficient 2	Setting range: 0-100.0, unit: 1.0% When the speed loop is set to 100.0%, PI control is adopted and the dynamic response is fast. When set to 0, the velocity loop integral has obvious effect and can filter low frequency interference, but the dynamic response is slow. By adjusting this coefficient, the speed loop can have better dynamic response and increase the resistance of low frequency interference.									
P02-19	Torque feed forward gain	Setting range: 0-30000, unit: 1.0% Set the weighting value of current loop feedforward. The parameter adds the current loop after weighting the differential of the speed instruction									
P02-20	Torque feed forward smoothing constant	Setting range: 0-64.00, unit: ms This parameter is used to set the torque feed forward filter time constant.									
P02-30	Gain switching mode	Setting range: 0-10 Set the first and second gain switching conditions <table border="1" style="width: 100%; border-collapse: collapse;"> <thead> <tr> <th style="width: 15%;">Value</th> <th style="width: 25%;">Switching conditions</th> <th style="width: 60%;">Remark</th> </tr> </thead> <tbody> <tr> <td style="text-align: center;">0</td> <td>Fixed for the first gain</td> <td>P02-00、 P02-10、 P02-11、 P02-12</td> </tr> <tr> <td style="text-align: center;">1</td> <td>Fixed for</td> <td>P02-01、 P02-13、 P02-14、 P02-15</td> </tr> </tbody> </table>	Value	Switching conditions	Remark	0	Fixed for the first gain	P02-00、 P02-10、 P02-11、 P02-12	1	Fixed for	P02-01、 P02-13、 P02-14、 P02-15
Value	Switching conditions	Remark									
0	Fixed for the first gain	P02-00、 P02-10、 P02-11、 P02-12									
1	Fixed for	P02-01、 P02-13、 P02-14、 P02-15									

			the second gain	
		2	use DI input switching	Need to set the DI port to 9 (gain switching input)  Invalid: first gain Effective: second gain
		3	Torque command is big	Switch to second gain when the torque instruction is greater than the threshold(determined by P02-31 and P02-32). Less than the threshold and when it exceeds the P02-33 delay setting, switch to the first gain.
		4	The speed instruction changes a lot.	Switches to the second gain when the speed instruction changes more than the threshold(determined by P02-31 and P02-32). Less than the threshold and when it exceeds the P02-33 delay setting, switch to the first gain.
		5	peed command is large.	Switch to second gain when the speed instruction is greater than the threshold(determined by P02-31 and P02-32). Switch to first gain when less than threshold, while exceeding P02-33 latency settings
		6	Large position deviation	Switch to second gain when the position deviation is greater than the threshold(determined by P02-31 and P02-32). Less than the threshold and when it exceeds the P02-33 delay setting, switch to the first gain.
		7	Have Location command.	Switch to second gain when there is a position command. The position command ends and when it exceeds the P02-33 delay setting, switch to the first gain.
		8	Location incomplete.	Switch to second gain when positioning is not complete. Location complete, while exceeding the P02-33 delay setting, switch to first gain
		9	Real speed is big	Switches to the second gain when the actual speed is greater than the threshold(determined by P02-31 and P02-32). Less than the threshold and when it exceeds the P02-33 delay setting, switch to the first gain.
		10	Location command + actual	Switch to second gain when there is a position command. There is no position instruction and the actual



		speed	speed is less than the threshold(determined by P02-31 and P02-32), and when the P02-33 delay setting is exceeded, switch to the first gain.
P02-31	Gain switching level	Set range: 0-20000 Judgment threshold for gain switching. Torque unit: 1000 bit = 25 % rated torque Speed unit: 1000 bit = 200 rpm Location Unit: 131072 bit per lap	
P02-32	Gain switching hysteresis	Set range: 0-20000 The hysteresis level during gain switching Torque unit: 1000 bit = 25 % rated torque Speed unit: 1000 bit = 200 rpm Location Unit: 131072 bit per lap	
P02-33	Gain switching delay	Set range: 0-1000 .0, unit: MS When switching from the second gain to the first gain, the time from the trigger condition to the actual switch is satisfied.	
P02-34	Position gain switching time	Set range : 0-1000.0, Unit: ms Position Control Gain 1 Smooth Switch to Position Control Gain 2	
P02-41	Mode Switch Level	Set range: 0-20000 Set the threshold for switching. Torque unit: 1000 bit = 25 % rated torque Speed unit: 1000 bit = 200 rpm Location Unit: 131072 bit per lap	
P02-50	Torque instruction plus calculation	Set range: -100.0-100, Unit 1.0 % Location control mode is valid. This value is superimposed on a given torque value and is used for static torque compensation of the vertical axis.	
P02-51	Forward torque compensation	Set range: -100.0-100 .,Unit1.0 % Location control mode is valid. Used to compensate for forward static friction	
P02-52	Reverse torque compensation	Set range: -100.0-100 .0, Unit 1.0 % Location control mode is valid. Used to compensate for reverse static friction	

#### 5.2.4 P03-xx Position parameters

Parameter code	name	Instruction
P03-00	Location Command Source	0: Pulse command 1: Numbers given, used for communication control.
P03-03	Inverse command pulse	Used to adjust pulse count direction 0: Normal. 1: Reverse direction
P03-04	Location Pulse Filter Settings	Setting range : 0-3, UNIT: us 0: 0.1us, 1: 0.4us 2: 0.8us,

		3: 1.6us
P03-05	Location complete judgment conditions	0: Output when position deviation is less than P03-06 setting 1: The position is given and the position deviation is less than the P03-06 setting output 2: Location given(filtered), and position deviation less than P03-06 set output
P03-06	Location complete range	Set range: 0-65535, units: encoder units Use to set the threshold value for positioning completion output. Using the incremental encoder motor, the number of encoder lines * 4 per loop is calculated.
P03-09	Number of command pulses for 1 motor rotation	Set range: 0-65535 Used to set the number of command pulses for the motor to rotate around. When this parameter is set to 0, the P03-10 and P03-11 parameters are valid.
P03-10	Molecular of electronic gear 1	The formula for calculating the electronic gear ratio of incremental encoder: $G = \frac{\text{Numerator}}{\text{Denominator} \times 4}$ eg: Encoder line quantity 2500; Input pulse quantity per rotation 3200; Encoder Motor C: Line of encoder: P: Input number per rotation of $G = \frac{2500 \times 4}{3200} = \frac{10000}{3200} = \frac{25}{8}$
P03-11	The denominator of electronic gear 1	Remark
P03-15	Position deviation too large setting	Setting range: 0-65535, unit: instruction unit *10  Set the number of pulses that are allowed to deviate it will alarm if beyond the set value. Example: set value is 20. When the following deviation exceeds 20*10, the driver will alarm AL.501 (the position deviation is too large).
P03-16	Position command smoothing constant	Setting range: 1000, unit: ms Set the time constant of the position instruction smoothing filter

#### 5.2.5 P04-xx Speed parameter

Parameter code	name	Instruction
P04-00	Speed command source	0: external analog instruction 1: digital instruction (parameter setting) 2: digital instruction (communication) 3: internal multiple sets of instructions
P04-02	Digital speed given value	Set range: -6000-6000, units: rpm When P04-00 is set to 1, P04-02 is the speed control setting value
P04-05	Overspeed alarm value	Set range: 0-6500, unit: rpm Set allowed maximum speed, exceeding set value will A.420 speed alarm
P04-06	Forward speed limit	Set range: 0-6000 in rpm Limit motor forward speed
P04-0	Reverse speed	Set range: 0-6000 in rpm

7	limit	Limit motor reverse speed
P04-1 0	Zero speed detection value	Set range: 0-200.0 in rpm Set the zero speed exit limit, the motor speed below the threshold can output the "motor zero speed output" signal through the output port
P04-1 4	acceleration time	Setting range: 0-10000, unit: 1ms/1000rpm Set the acceleration for speed control
P04-1 5	Deceleration time	Setting range: 0-10000, unit: 1ms/1000rpm Set the deceleration speed for speed control

5.2.6 P05-xx Torque parameters

Parameter code	name	Instruction
P05-1 0	Internal positive torque limit value	Setting range: 0-300.0, unit: 1.0% The forward output of the motor is limited, with 100 denoting 1 times torque and 300 denoting 3 times torque  When the torque output reaches the limit value, the output signal can be detected by the torque limit output on the DO port
P05-1 1	Internal torque limit value	Setting range: 0-300.0, unit: 1.0% Limited motor output, 100 represents 1 times torque, 300 represents 3 times torque When the torque output reaches the limit value, the output signal can be detected by the torque limit output on the DO port

5.2.7 P06-xx I/O Parameter

Parameter code	Name	Instruction
P06-0 0	Enable the output port to be effectively level	Setting range: 0-1, factory setting: 1
P06-2 0	Alarm output port effective level	Setting range: 0-1, factory setting: 1
P06-2 2	Put in place the output port effective level	Setting range: 0-1, factory setting: 1

5.2.8 P08-xx Advanced function parameters

Parameter code	Name	Instruction
P08-1 9	Feedback speed low-pass filtering constant	Setting range: 0-25.00, unit: ms The feedback speed low-pass filter time constant can be set to large when the motor is roaring during operation.
P08-2 0	Torque command filter constant	Setting range: 0-25.00, unit: ms Torque instruction filter time constant, when the motor running in the squealing, the value can be appropriately set to large.
P08-2	Disturbance torque	Setting range: 0-100.0

5	compensation gain	Gain coefficient of perturbation torque observation. The higher the value, the stronger the anti-disturbance torque capacity, but the motion noise may also increase.
P08-2 6	The perturbation torque filter time constant	Setting range: 0-25.00, unit: ms The larger the value, the stronger the filtering effect, can inhibit the motion noise. However, the effect of disturbance torque is affected by the phase delay.

**5.3 Monitor project list**

displaying serial number	Display item	Description	Unit
d00.C.PU	The sum of the position commands	This parameter can monitor the number of pulses sent by the user to the servo driver, so as to confirm whether any pulse loss occurs	Instruction unit
d01.F.PU	The sum of the position feedback pulses	This parameter can monitor the pulse number of the servo motor feedback. The unit is the same as the user input unit	Instruction unit
d02.E.PU	Number of position deviation pulses	This parameter can monitor the pulse number of position delay in the operation of the servo system. The unit is the same as the user input unit	Instruction unit
d03.C.PE	The position is given the sum of the pulses / Feedback pulse of gantry motor	This parameter can monitor the number of pulses sent by the user to the servo driver. Unit: when using absolute value motor, calculate at 131072bit for each turn. With the incremental encoder motor, the number of encoder lines per lap is *4.	Encoder unit/ Instruction unit
d04.F.PE	Position feedback pulse sum	This parameter can monitor the pulse number of the servo motor feedback. Unit: when using absolute value motor, calculate at 131072bit for each turn. With the incremental encoder motor, the number of encoder lines per lap is *4.	Encoder unit / Instruction unit
d05.E.PE	Position deviation pulse number /Gantry pulse deviation	This parameter can monitor the pulse number of position delay in the operation of the servo system. Unit: when using absolute value motor, calculate at 131072bit for each turn. With the incremental encoder motor, the number of encoder lines per lap is *4.	Encoder unit/ Instruction unit
d06.C.Fr	Pulse command input frequency	This parameter can monitor the input frequency of external pulse instruction	KPPS
d07.C.SP	Speed control instruction		rpm
d08.F.SP	Motor speed	This parameter can monitor the speed when the servo motor is running	rpm

d09. C.tQ	Torque command	This parameter can monitor the torque when the servo motor is running	%
d10. F.tQ	Torque feedback value	This parameter can monitor the torque feedback when the servo motor is running	%
d11.AG.L	The average torque	This parameter can monitor the servo motor's average torque for the past 10 seconds	%
d12.PE.L	Peak torque	This parameter can monitor the peak torque of the servo motor after power on	%
d13.oL	Overload load rate	This parameter can monitor the load occupancy of the servo motor for the past 10 seconds	%
d14.rG	Regenerative load factor	This parameter can monitor the load rate of regenerative resistance	%
d16.I.Io	Input IO state	This parameter can monitor the input port state of CN1. The upper vertical bar represents the high level (optocoupler cutoff), and the lower horizontal bar represents the low electro-optical coupling conduction). The corresponding relation with the input port is that the operation panel corresponds to di1-di4 from right to left	binary system
d17.o.Io	Output IO state	This parameter can monitor the output port state of CN1. The upper vertical bar represents the optical coupling lead, while the lower vertical bar represents the optical coupling cut-off. The corresponding relation with the output port is that the operation panel corresponds to do1-do3 from right to left	binary system
d18.AnG	Machine Angle	This parameter can monitor the motor mechanical Angle, rotation 1 turn is 360 degrees	0.1degree
d19.HAL	Motor UVW phase sequence	This parameter can monitor the phase sequence position of the incremental encoder motor	
d20.ASS	Absolute value encoder single coil number	This parameter can monitor the feedback value of the absolute encoder, rotating one circle as 0xffff	0-0xFFFF
d21.ASH	10/5000 Absolute value encoder multi-turn numerical value	This parameter can be used to monitor the number of turns of the absolute multi-coil encoder motor	
d22.J-L	Inertia ratio	This parameter can monitor the real-time inertia of the motor load	%
d23.dcp	Main circuit voltage (dc value)	This parameter can monitor the voltage value of the main circuit	V
d24.Ath	Driver temperature	This parameter can monitor drive temperature	degree centigrade

d25.tiE	Cumulative running time	This parameter can monitor the drive run time in seconds	Second
d26.1.Fr	Resonance frequency 1	This parameter can monitor the resonant frequency 1	Hz
d28.2.Fr	Resonance frequency 2	This parameter can monitor the resonant frequency 2	Hz
d30.Ai1	Analog quantity command 1 input voltage ( V_REF )	This parameter can monitor the speed loop's analog instruction (v-ref) input voltage value.	0.01V
d31.Ai2	Analog quantity command 2 input voltage ( T_REF )	This parameter can monitor the input voltage value of the analog instruction (t-ref) of the torque loop.	0.01V

## 6 、 Fault analysis and treatment

### 6.1 Fault alarm information table

Alarm type	The serial number code	Alarm content
A hardware failure	AL.051	EEPROM parameter anomaly
	AL.052	Programmable logic configuration failures
	AL.053	Initialization failed
	AL.054	A system exception
	AL.060	Product model selection fault
	AL.061	Product matching fault
	AL.062	Parameter storage failure
	AL.063	Overcurrent detection
	AL.064	The servo self - check found the output to ground short circuit fault
	AL.066	Servo unit control power supply low
	AL.070	AD sampling fault 1
	AL.071	Current sampling fault
	AL.100	Parameter combination anomaly
	AL.101	AI setting fault
	AL.102	DI distribution fault
	AL.103	DO allocation fault
	AL.105	Error setting of electronic gear
	AL.106	Abnormal output setting of frequency division pulse
	AL.110	The parameters should be reset
	AL.120	Invalid alert for servon command
	AL.401	Under voltage
	AL.402	Over voltage
	AL.410	Overload (instantaneous maximum load)
	AL.411	Driver overload
	AL.412	Motor overload (maximum continuous load )
	AL.420	Over speed
	AL.421	Out of control check out
AL.422	Speed fault	
AL.425	AI sampling voltage is too high	

	AL.435	Impulse current limits resistance overload
	AL.436	DBoverload
	AL.440	Radiator overheating
	AL.441	Motor overheat fault
	AL.500	Frequency division pulse output overspeed
	AL.501	Excessive deviation of position
	AL.502	Full closed - loop encoder location and motor location deviation is too large
	AL.505	P command input pulse exception
	AL.550	Failure identification of inertia
	AL.551	Return to origin timeout fault
	AL.552	Angle to identify failed faults
Encoder fault	AL.600	Short circuit fault of encoder output power
	AL.610	Incremental decoder offline
	AL.611	Incremental encoder Z signal loss
	AL.620	Bus type encoder off line
	AL.621	Read/write motor encoder EEPROM parameter abnormal
	AL.622	Motor encoder EEPROM data verification error
Warning	AL.900	Excessive deviation of position
	AL.901	The position deviation of the servo ON is too large
	AL.910	Motor overload
	AL.912	Driver overload
	AL.941	Parameter changes that require reconnection
	AL.942	Write EEPROM frequent warning
	AL.943	Serial communication exception
	AL.950	Overpass warning
	AL.971	Undervoltage warning

## 6.2 Fault alarm reason and disposal

### AL.051: EEPROMparameter anomaly

Fault alarm reason	Fault alarm check	Treatment measure
Server EEPROM data exception	Check the wiring	Correct wiring and recharge If always present, change the drive

### AL.053: Failure to initialize

Fault alarm reason	Fault alarm check	Treatment measure
Main control failed to initiate power on MCU	Check the wiring Back to electricity	If always present, change the drive

### AL.063: Overcurrent detection

Fault alarm reason	Fault alarm check	Treatment measure
The power module of servo unit has excessive current	Is there a short circuit in U,V,W connection Is there a short circuit between B1 and B3	Correct connection If always present, change the drive

### AL.071: Current sampling fault

Fault alarm reason	Fault alarm check	Treatment measure
Abnormal sampling data of current sensor	Is the connection correct	Correct connection If always present, change the

		drive
--	--	-------

**AL.100: Parameter combination anomaly**

Fault alarm reason	Fault alarm check	Treatment measure
Parameter setting error	Check the parameters set (p03-07)	Set the parameters correctly If always occurs, do parameter initialization

**AL.102: Distribution of the fault**

Fault alarm reason	Fault alarm check	Treatment measure
At least two input ports have the same function selection	Check port input function to select parameters	Set the parameters correctly The drive is reenergized

**AL.103: DO Distribution of the fault**

Fault alarm reason	Fault alarm check	Treatment measure
At least two output ports have the same function selection parameters	Check port output function to select parameters	Set the parameters correctly The drive is reenergized

**AL.105: Electronic gear setting error**

Fault alarm reason	Fault alarm check	Treatment measure
Error setting of electronic gear ratio	Check the setting parameters of the electronic gear ratio.P03-10,P03-11	Set the electronic gear ratio correctly
The output pulse of the gantry is set too small	Check the number of feedback pulses for one rotation of the gantry motor: p03-52 must be larger than 128	Correctly set the number of feedback pulses for the rotation of one function motor in Longmen.

**AL.110: The parameters should be reset**

Fault alarm reason	Fault alarm check	Treatment measure
After setting the servo parameters, it needs to be reenergized to take effect	Re-power the driver	Re-power the driver

**AL.401: Under voltage**

Fault alarm reason	Fault alarm check	Treatment measure
The input voltage of the main circuit is lower than the rated voltage or no input voltage	Check whether the input wiring of the main loop is correct and what voltage is	Ensure correct wiring and use the correct voltage source or series connection stabilizer

**AL.402: Over voltage**

Fault alarm reason	Fault alarm check	Treatment measure
The input voltage of the main circuit is higher than the rated voltage	Use the voltmeter to test whether the input voltage of the main circuit is correct	Use the correct voltage source or serial voltage stabilizer
Driver hardware fault	When it is determined that the input voltage is correct, the alarm is still over voltage	Please send it back to the dealer or the original factory for inspection
The regenerative resistance is not connected or the regenerative resistance is not	Verify that p00-30 is set to 0 or 1	Correct setting and external regenerative resistance



selected correctly		
--------------------	--	--

**AL.410: Overload (instantaneous maximum load)**

Fault alarm reason	Fault alarm check	Treatment measure
The machine is stuck when the motor starts	Check if mechanical connections are stuck	Adjust mechanical structure
Driver hardware failure	Verify that the mechanical part is normal and still alarm	Please send it back to the dealer or the original factory for inspection

**AL.412: Motor overload (continuous maximum load)**

Fault alarm reason	Fault alarm check	Treatment measure
Use continuously beyond the rated load of the driver	It can be monitored through d13.ol in the monitoring mode	Change the motor or reduce the load
Improper parameter setting of control system	1. Whether the mechanical system is installed 2. The acceleration setting constant is too fast 3. Whether the gain class parameters are set correctly	1. Adjust the control loop gain 2. Set time for acceleration and deceleration to slow down
Motor wiring error	Check U, V, W connection	Correct connection

**AL.420: Over speed**

Fault alarm cause	Fault alarm check	The disposal measures
The input speed command is too high	Use a signal detector to check if the input signal is normal	Adjust the frequency of the input signal
Incorrect parameter setting for overspeed determination	Check whether p04-05 (speed alarm value) is set properly	Set p04-05 correctly (alarm value for overspeed)

**AL.440: Radiator overheating**

Fault alarm cause	Fault alarm check	treatment measure
Drive internal temperature higher than 95 度	Check the heat dissipation condition of the drive	Improve the heat dissipation condition of the drive. If the alarm occurs again, please send the drive back to the original factory for inspection

**AL.501: Position error is too big**

Fault alarm reason	Fault alarm check	The disposal measures
The location deviation is too large and the parameter setting is too small	Confirm the parameter setting of p03-15 (location deviation is too large)	Increase the p03-15 (position deviation is too large) setting value
The gain is set too small	Verify that the gain class parameters are set properly	Reset the gain class parameters correctly
Internal torque limit setting is too small	Confirm the internal torque limit value	Adjust the internal torque limit value correctly
Excessive external load	Check external load	Reduce load or replace power motor

**AL.505: P Command input pulse exception**

Fault alarm reason	Fault alarm check	The disposal measures
The pulse command frequency is higher than the	The pulse frequency meter is used to detect whether the	Set the input pulse frequency correctly

rated input frequency	input frequency is higher than the rated input frequency	
-----------------------	--	--

AL.610: Incremental decoder offline

Fault alarm reason	Fault alarm check	The disposal measures
Incremental encoder HallU, HallV, HallW signal anomaly	Check the encoder wiring	correct wiring

AL943: 6/5000

Serial communication exception

Fault alarm reason	Fault alarm check	The disposal measures
Serial communication interference The baud rate of serial port is set too high	Check the wiring Check the baud rate parameter p00-21 for serial communication	Add a filter to the wire Reduce the baud rate of serial communication

## 7、Control signal connection

### 7.1 Control signal single terminal common anode connection

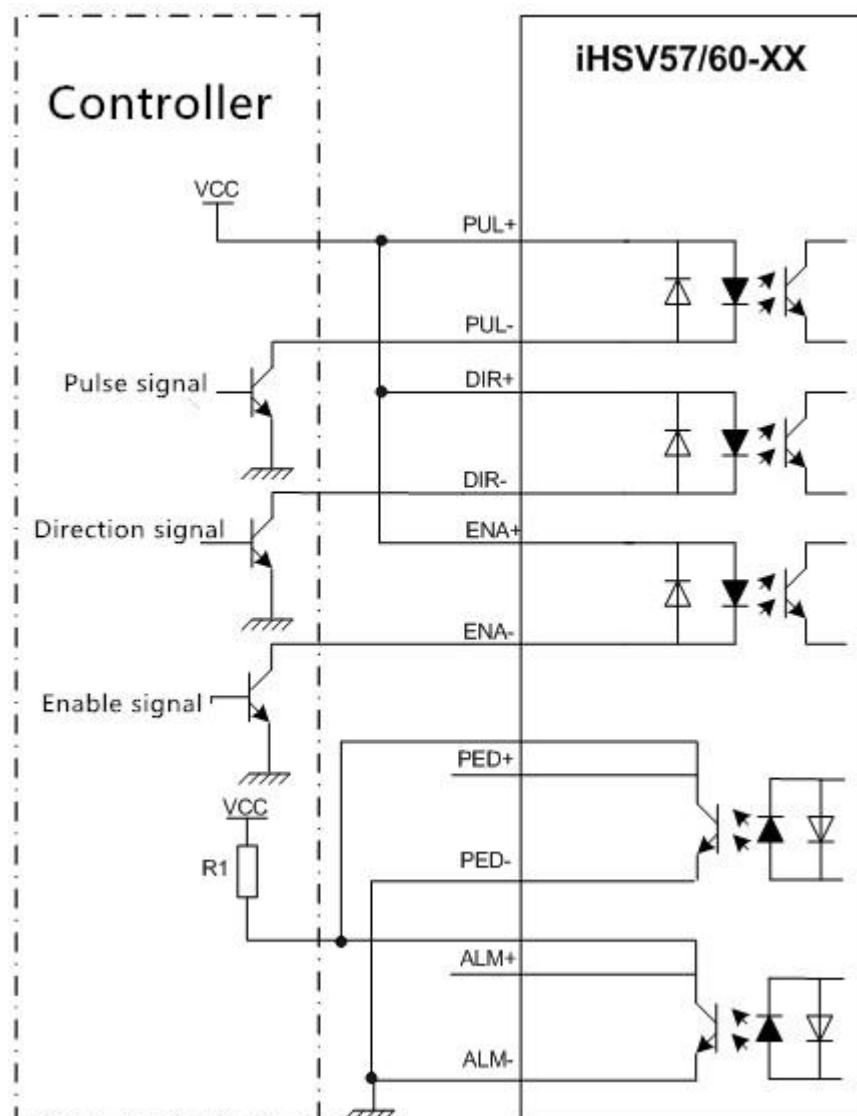

Note:

VCC is compatible with 5V~24V.

The resistance R1 is connected to the control signal terminal, and the resistance value is 3~5K.

### 7.2 Control signal single terminal common cathode connection

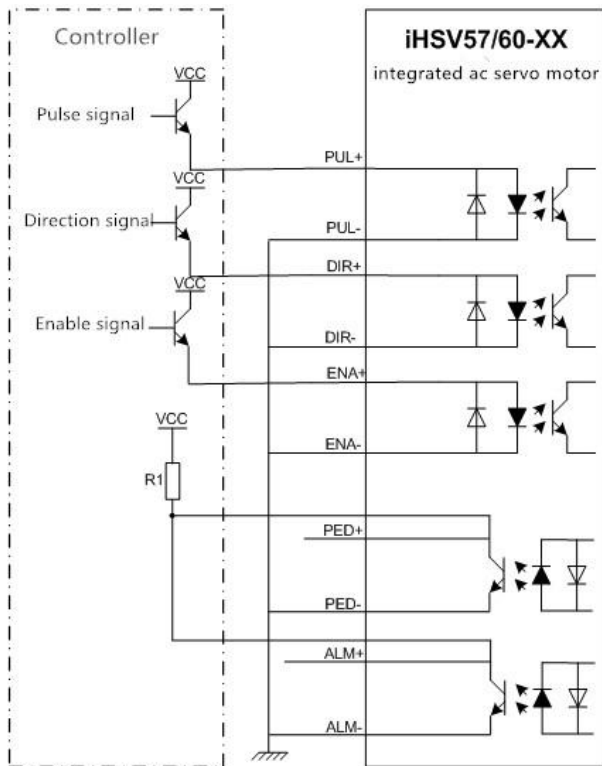

Note:

VCC is compatible with 5V~24V.

The resistance R1 is connected to the control signal terminal, and the resistance value is 3~5K.

### 7.3 Control signal differential connection mode

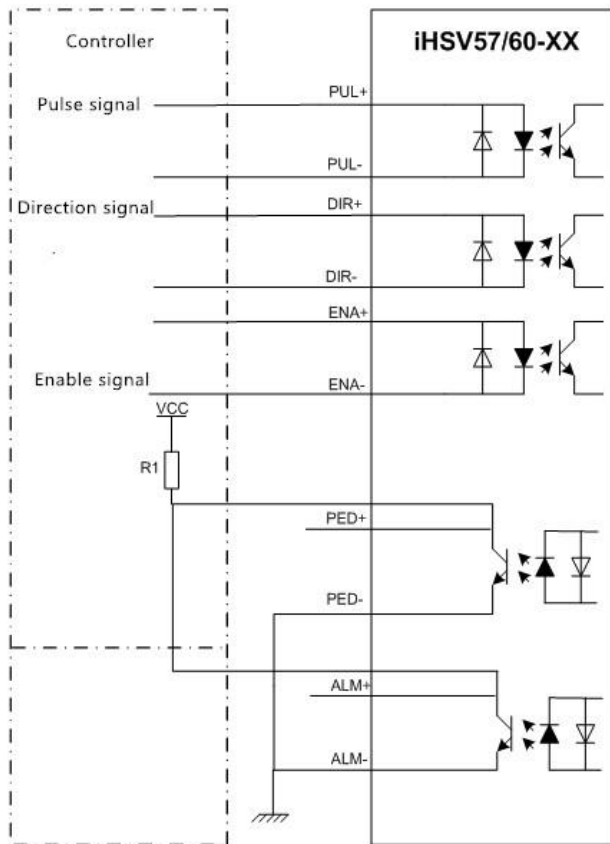

Note:VCC is compatible with 5V~24V.The resistance R1 is connected to the control signal terminal, and the resistance value is 3~5K.

#### 7.4 232 Serial communication wiring diagram

Definition	Description	Color connection for 232 serial communication lines
NC	hang in the air	
RX	receiving end	Brown and white

GND	Power-	Blue
TX	The sender	Blue and white
VCC	Power +	

### 7.5 Control signal sequence diagram

In order to avoid some wrong actions and deviations, PUL, DIR and ENA should meet certain requirements, as shown in the figure below:

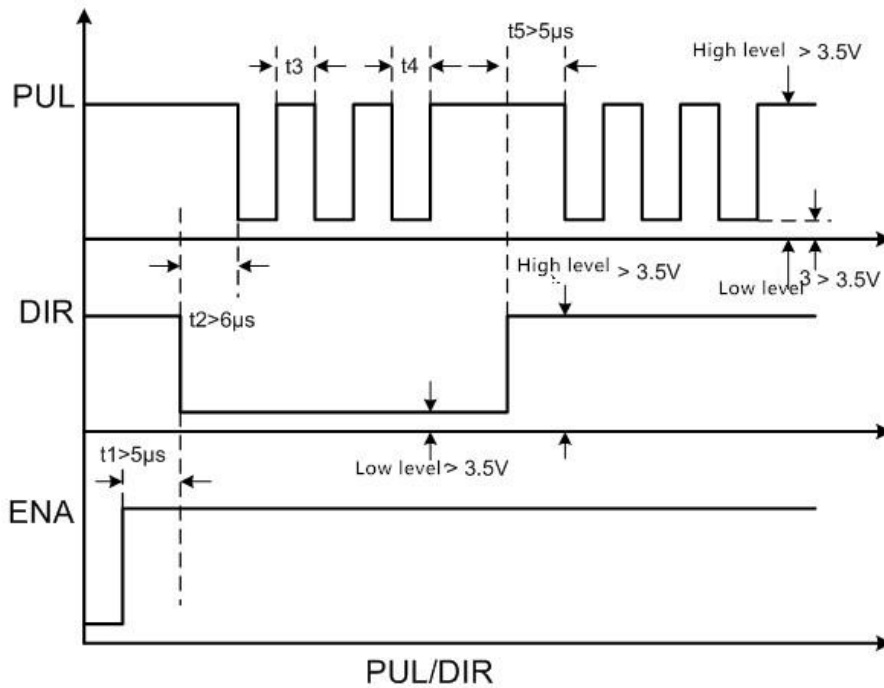

**Remark:**

- (1)  $t_1$ : ENA (enabling signal) should be at least 5  $\mu$ s ahead of time, which is determined to be high. It is generally recommended that ENA+ and ENA- be suspended.
- (2)  $t_2$ : DIR at least predates the PUL count edge 6, indicating that the state is high or low.
- (3)  $t_3$ : the pulse width shall not be less than 2.5  $\mu$ s.
- (4)  $t_4$ : the width of low level is not less than 2.5  $\mu$ s.

**7.6 Servo motor speed torque characteristic curve**

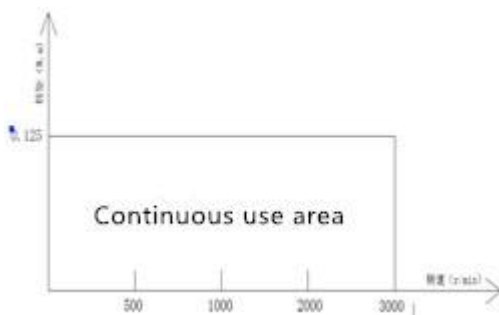

iHSV42-40-05-24-XXX4/5000 Torque characteristics

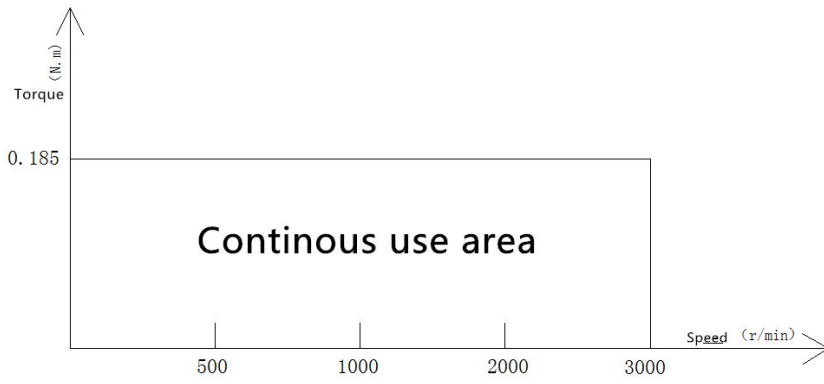

iHSV42-40-07-24-XXX4/5000 Torque characteristics

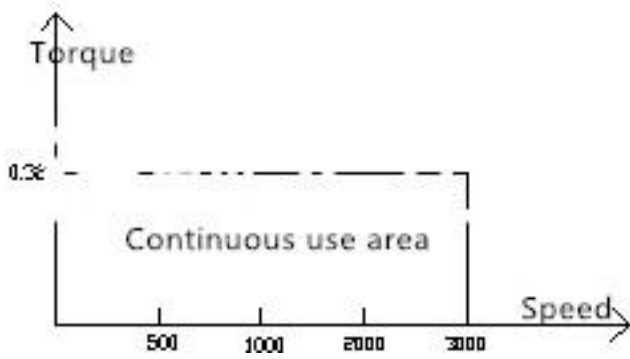

iHSV57-30-10-36-XXX4/5000 Torque characteristics

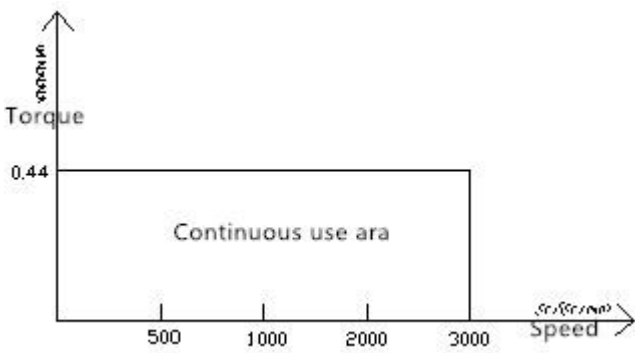

iHSV57-30-14-36-XXX4/5000 Torque characteristics

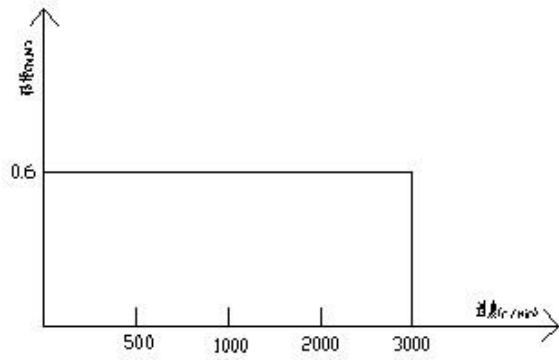

iHSV57-30-18-36-XXX4/5000 Torque characteristics

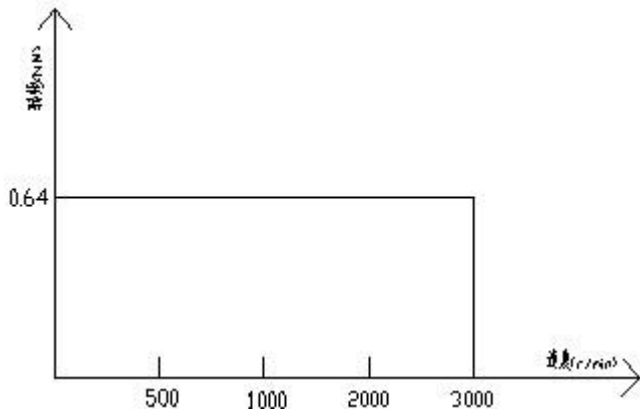

iHSV60-30-20-36-XXX4/5000 Torque characteristics

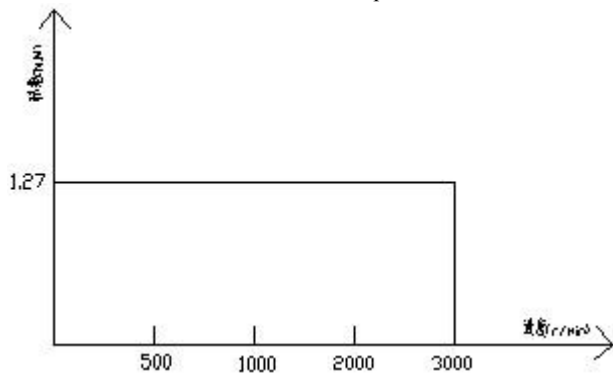

iHSV60-30-40-48-XXX4/5000 Torque characteristics



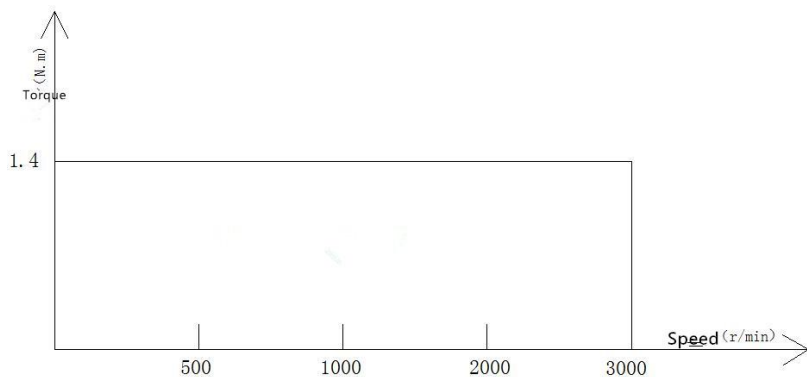

iHSV86-30-44-48-XXX4/5000 Torque characteristics

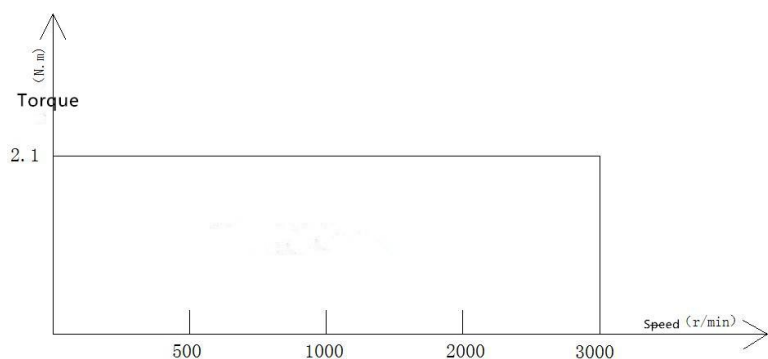

iHSV86-30-66-72-XXX4/5000 Torque characteristics

## 8. Setting of dial code for subdivision

### 8.1 Subdivision Settings

The subdivision Settings are as follows: when SW1, SW2, SW3 and SW4 are all set as on, the user's customized subdivision is effective, and this value can be set by our company's servo software.

Drawing codes switch Subdivision	SW1	SW2	SW3	SW4
Default	on	on	on	on
800	off	on	on	on
1600	on	off	on	on
3200	off	off	on	on
6400	on	on	off	on
12800	off	on	off	on
25600	on	off	off	on
51200	off	off	off	on
1000	on	on	on	off
2000	off	on	on	off
4000	on	off	on	off
5000	off	off	on	off
8000	on	on	off	off

10000	off	on	off	off
20000	on	off	off	off
40000	off	off	off	off

### 8.2 Input edge Settings

SW5 dial code switch sets input edge, off means rising edge and on means falling edge.

### 8.3 Logical direction setting

When SW6 dial code switch off or on, the direction of current motor motion can be changed, off = CCW (forward), on=CW (reverse).

## 9、 Error alarm and LED flashing frequency

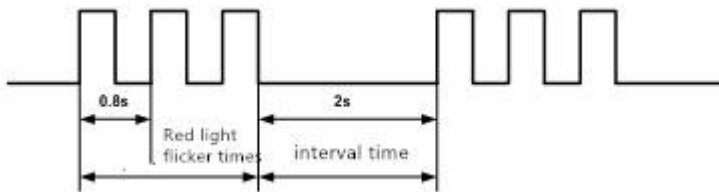

Number of red light flashes	Alarm Description	Treatment measures
2	Driver overcurrent	Is there a short circuit in the motor UVW line
3	Drive position deviation exceeds set value	Check if driver "deviation in place" parameter is set correctly
4	Drive encoder alarm	Check whether the encoder wire is properly connected
7	Driver overload	Check whether the motor UVW wire is connected correctly

## 10. Installation Dimensions

Mounting dimensions (unit: mm )

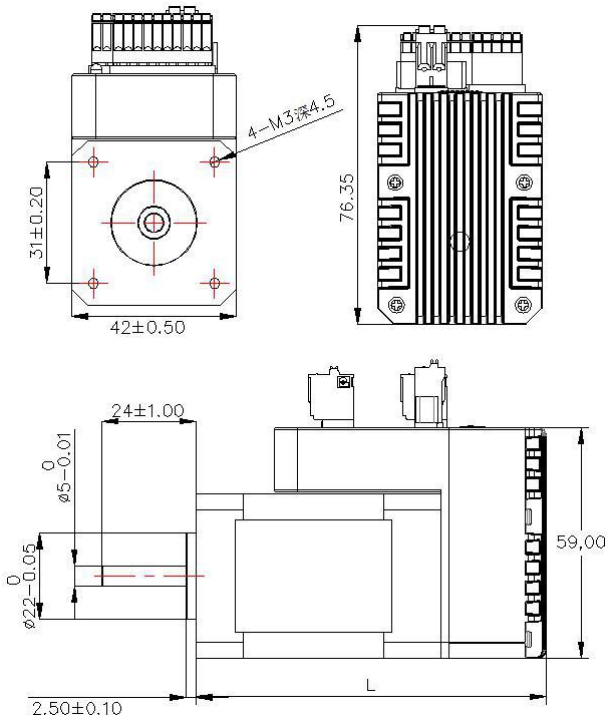

iHSV42-XX Mounting dimensions

Model	Length L ( mm )	shaft ( mm )
iHSV42-40-05-24-XXX	84	24
iHSV42-40-07-24-XXX	110	

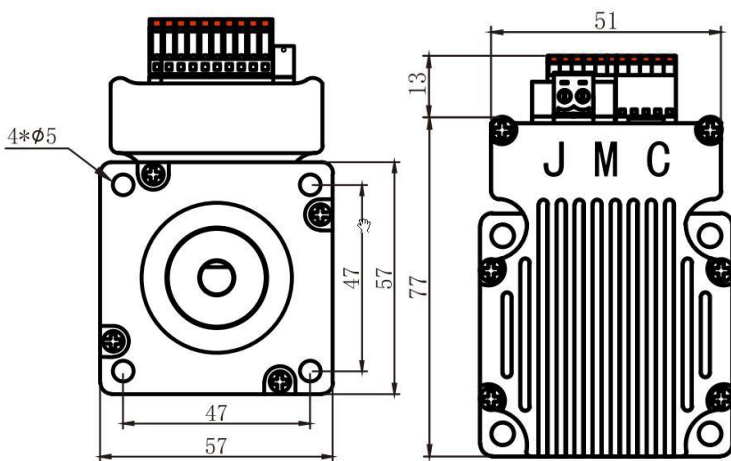

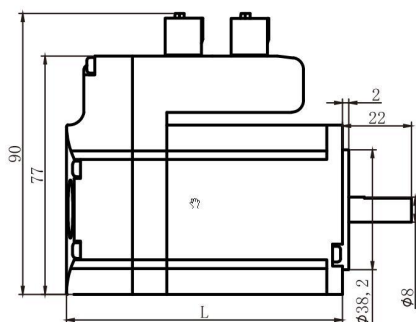

iHSV57-XX Mounting dimensions

Model No.	Length L ( mm )	shaft ( mm )
iHSV57-30-10-36-01-T-33-XXX	110	33
iHSV57-30-14-36-01-T-33-XXX	130	
iHSV57-30-18-36-01-T-33-XXX	150	

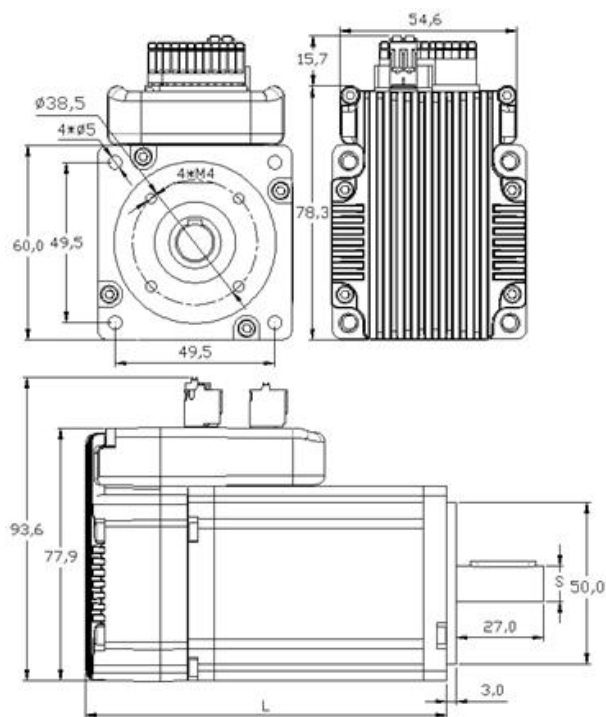

iHSV60-XX Mounting dimensions

Model No.	Length L ( mm )	diameter of Shaft S(mm)	Shaft length ( mm )
iHSV60-30-20-36-XXX	110	11	30
iHSV60-30-20-36-03-XXX	130	14	
iHSV60-30-40-36-XXX	110	14	

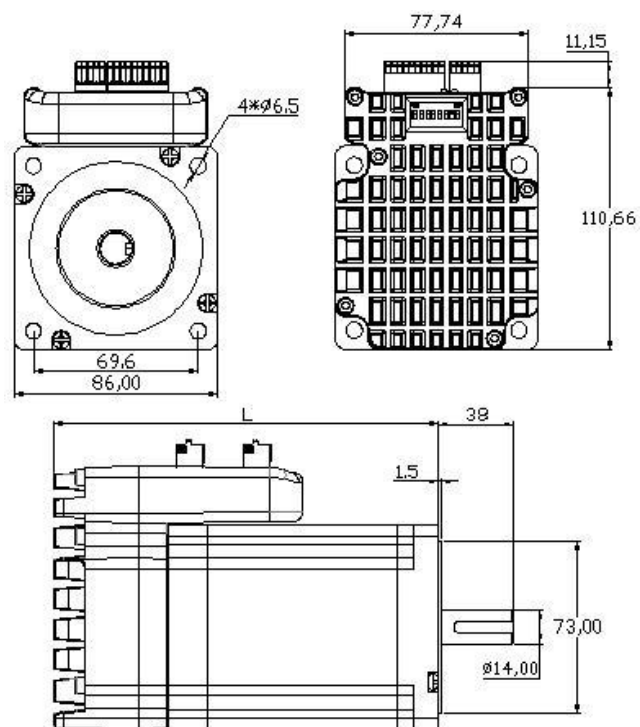

iHSV86-XX Mounting dimensions

Model	Lenght L ( mm )	Shaft ( mm )
iHSV86-30-44-48-XXX	162	38
iHSV86-30-66-72-XXX	189	

## 11、RFQ and analysis

### 11.1 Power lamp is not on

Check whether the power supply has input and whether the line connection is correct.

Whether the input voltage is too low.

High input voltage will burn out the servo drive motor.

### 11.2 power on the red light to alarm

Whether the input voltage of servo drive motor is too high or too low.

Whether the servo drive motor has pulse input all the time before power on, resulting in overshoot alarm.

### 11.3 Run a small Angle of rotation after the red light alarm

In the configuration parameters of the servo drive motor, whether the pole logarithm of the motor and the number of lines of the encoder are matched (the pole logarithm is: 4, and the number of lines of the encoder is: 1000).

If the pulse input speed is greater than the motor's rated speed, the position is out of tolerance.

### 11.4 the pulse does not rotate after input

Whether the connection of the pulse input terminal of the servo drive motor is reliable.

Whether the servo drive motor can be released, whether the energy signal has input.

The electronic gear ratio is too large.

## 12、iHSV42/57/60/86-XX Parameter modification steps

1、Choose JmcServoPcControl Servo adjust software, Double-click to open the following image：

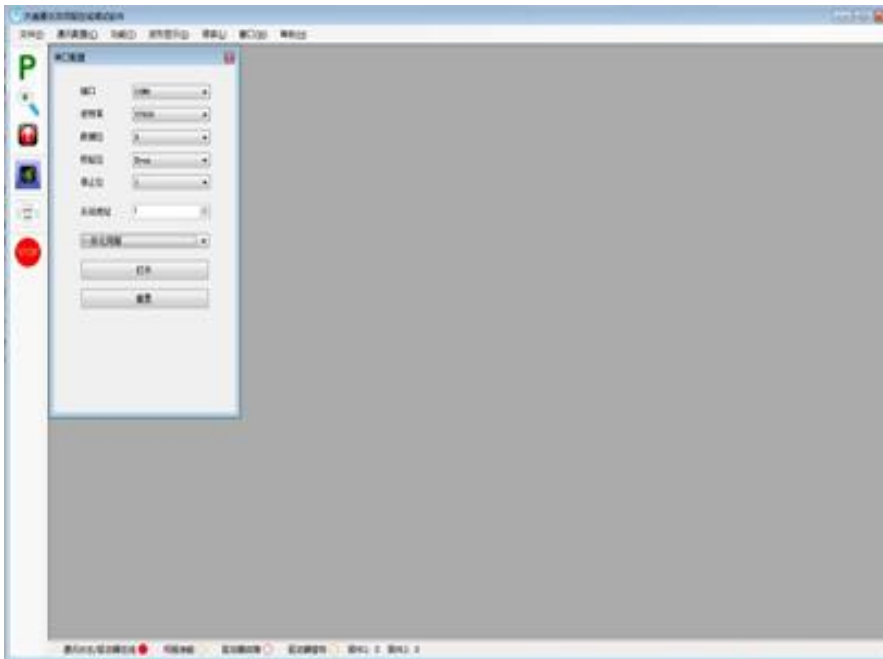

2、 In the popup dialog box, set the corresponding options and open at the point, as shown below:



3. If the communication is successful, the following figure shows:

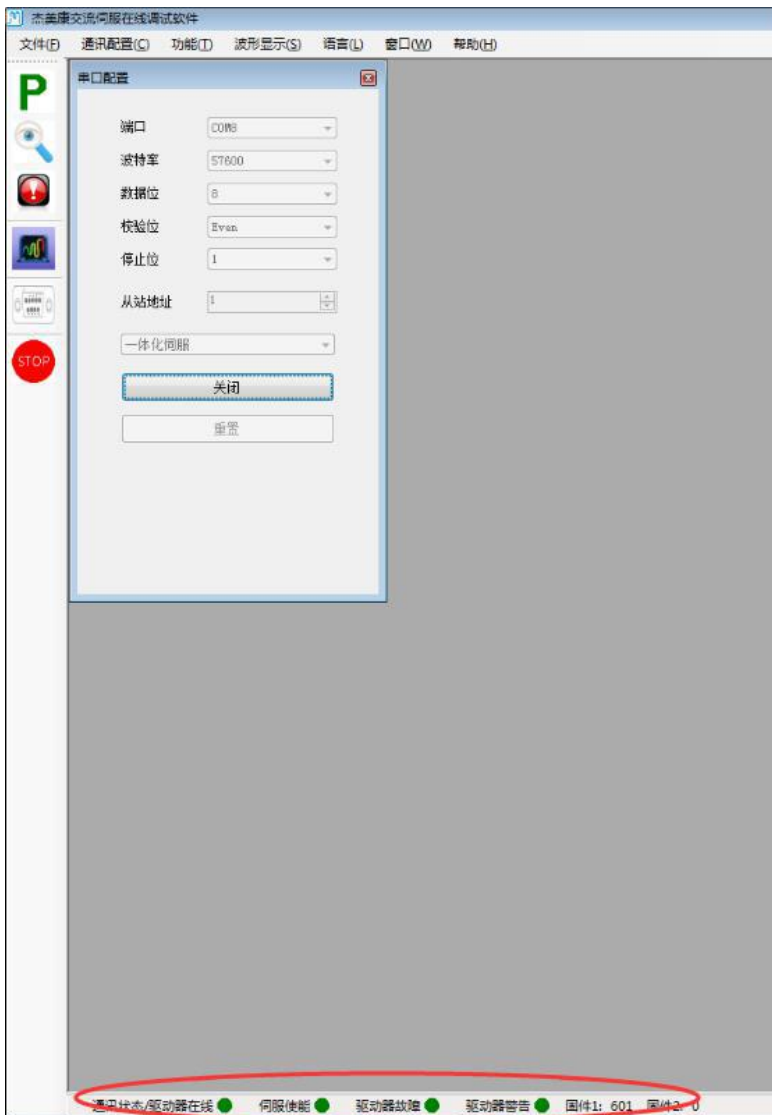

**Note:** If the connection is not available, please confirm whether COM port is selected correctly, whether the communication line is connected properly, and then reconnect according to the above steps. **Click the upper left option P**, Then pop up the following window, then the internal parameters of the driver will be uploaded automatically. After uploading, customers can change the parameters according to their needs.



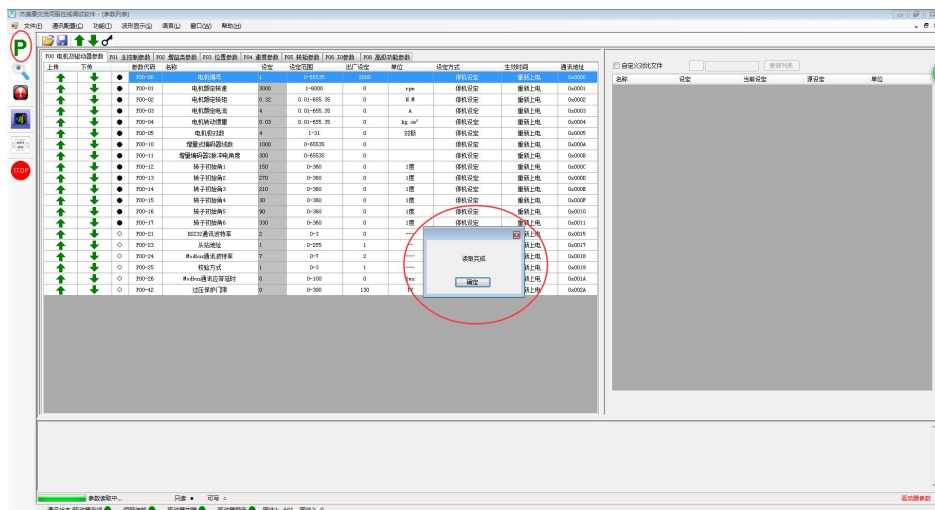

**Note:** P00-xx is parameters of the motor and drive . The factory has been set up, and will not be changed by customers. The following three steps are taken as follows: modify, download, upload, as shown in the following figure:

P00 电机及驱动器参数	P01 主控制参数	P02 增益类参数	P03 位置参数	P04 速度参数	P05 转矩参数	P06 IO参数	P08 高级功能参
上传	下传	参数代码	名称	设定	设定范围	出厂设定	单位
↑	↓	P01-01	控制模式设定	0	0-6	0	
↑	↓	P01-02	实时自动调整模式	3	0-3	1	
↑	↓	P01-03	实时自动调整刚性设定	13	0-31	13	
↑	↓	P01-04	转动惯量比	3	0-100.00	3	
↑	↓	P01-30	抱闸指令-伺服OFF延迟时间(抱...	100	0-255	50	
↑	↓	P01-31	抱闸指令输出的速度限制值	100	0-3000	100	
↑	↓	P01-32	伺服OFF抱闸指令等待时间	100	0-255	50	

**Note:** After setting the corresponding parameters in the settings, download the changed parameters to the driver according to the download option, and then upload the parameters to the interface to verify whether the parameters have changed.